

2006 Buell XB12Ss Lightning Long

SPECIFICATIONS AND PERFORMANCE DATA



ENGINE

Type:air-cooled, 45° V-twin
 Valvetrain:.....OHV, 2 valves per cyl.,
 hydraulic lifters, self-adjusting
 Displacement:1203cc
 Bore/stroke:88.9mm x 96.82mm
 Compression ratio:10.0:1
 Fuel system:.....Fuel injection,
 downdraft DDFI, 49mm throttle body
 Exhaust:2-1 w/variable
 backpressure valve

DRIVE TRAIN

Transmission:5-speed
 Final drive: Goodyear Hibrex belt
 RPM @ 65* mph/redline: ..3440/6600
 *actual, not indicated

DIMENSIONS

Wheelbase:54.4"
 Rake/trail:steering head 23.5°,
 fork 22°/4.7"
 Ground clearance:4.6"
 Seat height :.....32.5"
 GVWR:850.0 lbs.
 Wet weight:470.5 lbs.
 Carrying capacity:379.5 lbs.

SUSPENSION

Front: 43mm Showa inverted cartridge
 forks, adj. preload, comp. and reb.
 damping, 4.72" travel
 Rear: direct-acting remote-reservoir
 monoshock, externally adj. preload,
 plus adj. comp. and reb. damping,
 4.97" travel

BRAKES

Front:single 375mm. rim-mounted,
 semi-floating disc, six-piston, double-
 action caliper
 Rear:240mm disc,
 single-piston, single-action caliper

TIRES & WHEELS

Front:120/70ZR17 Dunlop
 D208F on 3.50" x 17" wheel
 Rear:180/55ZR17 Dunlop
 D208M on 5.50" x 17" wheel

ELECTRICS

Battery:12V, 12AH
 Ignition:3-D digitally mapped
 Headlight: dual 55W, one low, one high

FUEL

Tank capacity:4.4 gal.
 High/low/avg. mpg: 47.1/40.0/49.9



PERFORMANCE

Measured top speed126.8 mph
 0-1/4 mile12.02 sec.
 @ 110.69 mph
 0-60 mph3.88 sec.
 0-100 mph10.17 sec.
 60-0 mph117.9'
 Power to Weight Ratio1:5.81
 Speed @ 65 mph indicated:62.0

M/C RATING SYSTEM

EXCELLENT
 VERY GOOD
 GOOD
 FAIR
 POOR

----- Open Standard -----

Engine ●●●●○
 Transmission ●●●●○
 Suspension ●●●●○
 Brakes ●●●●○
 Handling ●●●●○
 Styling ●●●●○
 Riding Impression ●●●●○
 Instruments/Controls ●●●●○
 Attention to Detail ●●●●○
 Value ●●●●○

OVERALL RATING ●●●●○

ERGONOMICS TEMPLATE

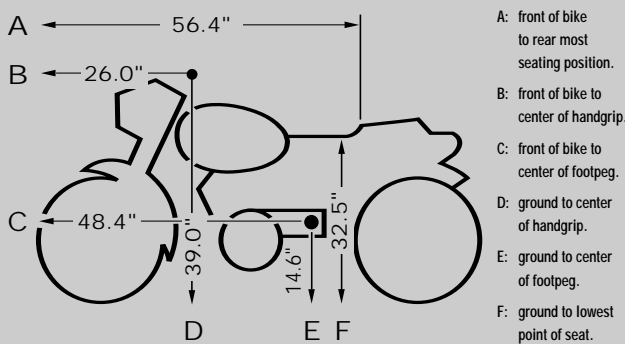

MISCELLANEOUS

Instruments:Analog speedo &
 tach, clock, digital odometer, dual trip-
 meters, plus miles traveled on reserve
 Indicators: hi-beam, t/s, neutral,
 low fuel, oil pressure, check engine
 MSRP:\$10,495
 Routine service interval:.....2500 mi.
 Valve adj. interval:not needed
 Warranty:24 mo., unlimited miles
 Colors:Barricade Orange,
 Midnight Black

DYNAMOMETER DATA

Low end ●●●●○
 Mid-range ●●●●○
 Top end ●●●●○

Buell's 1203cc V-twin gets great fuel economy but has some noticeable vibration between 50-60 mph in top gear despite its Uniplanar mounting. Also, it EFI programming makes engine braking less effective, requiring compensation with the brakes.

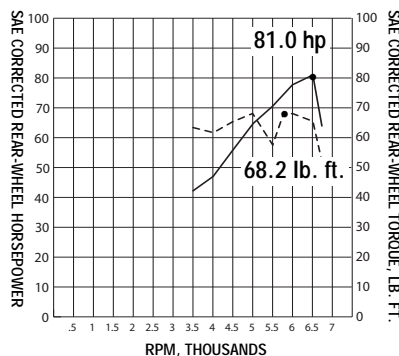

TEST NOTES

PICKS

- Plenty of grunt with exceptional fuel economy
- Very good suspension for a compliant yet sporty ride
- Excellent seat comfort for long hours of riding

PANS

- Handling isn't neutral, it wants to fall into turns
- Mirrors blur badly with vibration
- Restricted steering lock requires low-speed caution

STANDARD MAINTENANCE

Item	Time	Parts	Labor
Oil & Filter	0.3\$6.99 + \$14	\$18.00
Air Filter	0.2\$22.99\$12.00
Valve Adjustnot adjustable	
Battery Access	0.1MF\$6.00
Final Drivenot adjustable	
R/R Rear Whl.	0.8\$48.00
Change Plugs	0.3\$10.98\$18.00
Synch EFI	0.6\$36.00
Totals	2.3	\$54.96	\$138.00

Note: MCN Labor rate changed to \$60/hr. from \$54/hr. in May 2002