

2006 Yamaha YZF600R



SPECIFICATIONS AND PERFORMANCE DATA

ENGINE

Type:liquid-cooled, inline four
 Valvetrain:DOHC, 4 valves per cyl.
 shim-under-bucket valve adjustment
 Size:599cc
 Bore/stroke:62mm x 49.6mm
 Comp. ratio:12:1
 Carburetion:Keihin CV Downdraft
 36mm x 4 with ram-air induction
 Exhaust:4-2-1

DRIVETRAIN

Transmission:6-speed
 Final drive:#525 O-ring chain
 RPM @ 65* mph/redline: 5343/13,900
 *actual, not indicated

DIMENSIONS

Wheelbase:55.7"
 Rake/trail25.0°/3.82"
 Ground clearance:5.12"
 Seat height:31.8"
 GVWR:868 lbs.
 Wet weight:490 lbs.
 Carrying capacity:378 lbs.

SUSPENSION

Front:41mm telescopic fork
 adj. preload, comp. and reb. damping
 5.1" travel
 Rear:single shock w/ reservoir
 adj. preload, comp. and reb. damping
 4.7" travel

BRAKES

Front:dual 298mm discs
 Sumitomo four-piston calipers
 Rear:single 245mm disc
 single-piston caliper

TIRES & WHEELS

Front:120/60-ZR17 Bridgestone
 Battlax BT57 3.50" x 17" wheel
 Rear:160/60-ZR17 Bridgestone
 Battlax BT57 on 5.00" x 17" wheel

ELECTRICS

Battery:12V, 8AH
 Ignition:digital TCI
 Headlight:dual 60/55W

FUEL

Tank capacity:4.5 gal.
 Fuel octane recommended: 86[R+M/2]
 High/low/avg. mpg:44.1/41.9/43.3



PERFORMANCE

Measured top speed147.3 mph
 0-1/4 mile12.01 sec.
 @ 115.17 mph
 0-60 mph4.12 sec.
 0-100 mph9.43 sec.
 60-0 mph119.4'
 Power to Weight Ratio1:5.98
 Speed @ 65 mph (indicated) ...59.6

M/C RATING SYSTEM

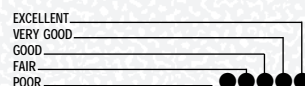

--- Middleweight Sportbike ---

Engine	●●●○
Transmission	●●●○
Suspension	●●●●
Brakes	●●●●
Handling	●●●○
Styling	●●●○
Riding Impression	●●●○
Instruments/Controls	●●●○
Attention to Detail	●●●○
Value	●●●○

OVERALL RATING ●●●○

ERGONOMICS TEMPLATE

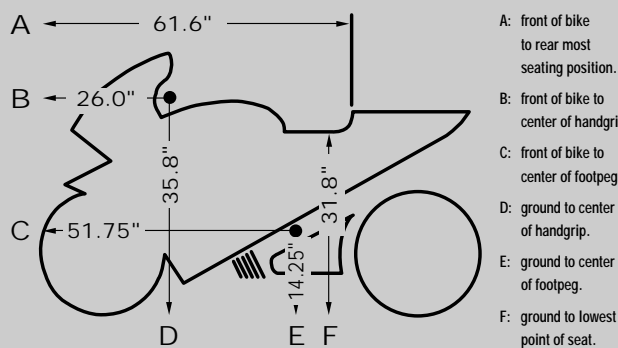

MISCELLANEOUS

Instruments: ..analog tachometer and speedometer, odometer, tripmeter, coolant temp.
 Indicators:hi-beam, t/s, neutral, low fuel, low oil pressure
 MSRP:\$7099
 Routine service interval:.....4000 mi.
 Valve adj. interval:.....26,600 mi.
 Warranty:.....12 mo., unlimited miles.
 Colors:Blue/White, Raven

DYNAMOMETER DATA

Low end ●●●○
 Mid-range ●●●○
 Top end ●●●○

The YZF600R shows its age with the lowest power and redline in the group. Vibration migrates from the seat to the controls at 5000-8000 rpm and the engine sounds "loose." Also we noted backfiring when shutting off from high rpm.

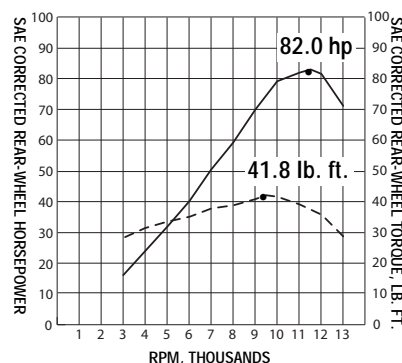

TEST NOTES

PICKS

- Most comfortable seat and highest handlebars
- Excellent and confidence-inspiring high speed handling
- A plush ride from its fully adjustable suspension

PANS

- Notchy transmission matched to a clutch with poor feel
- Looks the most dated compared to its competition
- Fifty pounds heavier it also has the weakest motor here

STANDARD MAINTENANCE

Item	Time	Parts	Labor
Oil & Filter	1.0	\$14.75/\$20	\$60.00
Air Filter	0.5	\$43.00	\$30.00
Valve Adjust	3.6	\$100.79	\$216.40
Battery Access	0.2	MF	\$12.00
Final Drive	0.2		\$12.00
R/R Rear Whl.	1.0		\$60.00
Change Plugs	0.5	\$18	\$30.00
Adjust carbs	2.0		\$120.00
Totals	9.0	\$196.54	\$540.00