

2006 Honda CBR600F4i



SPECIFICATIONS AND PERFORMANCE DATA

ENGINE

Type:liquid-cooled,
in-line 4-cylinder
Valvetrain:DOHC, 4 valves per cyl.,
shim-under-bucket valve adjustment
Size:599cc
Bore/stroke:67mm x 42.5mm
Comp. ratio:12.0:1
Carburetion:38mm throttle
bodies x 4 with ram-air induction
Exhaust:.....4-2-1

DRIVETRAIN

Transmission:6-speed
Final drive:#525 chain,
RPM @ 65* mph/redline:5513/14,500
*actual, not indicated

DIMENSIONS

Wheelbase:54.5"
Rake/trail24.0°/3.78"
Ground clearance:5.25"
Seat height :31.5"
GVWR:820 lbs.
Wet weight:440 lbs.
Carrying capacity:380 lbs.

SUSPENSION

Front:43mm cartridge fork,
adj. preload, comp. and reb. damping,
4.7" travel
Rear: single shock,
adj. preload, comp. and reb. damping,
4.7" travel

BRAKES

Front:dual 296mm discs,
four-piston, double-action calipers
Rear:220mm disc,
single-piston caliper

TIRES & WHEELS

Front:120/70-ZR17 Dunlop
D207 Sportmax on 3.5" x 17" wheel
Rear:.....180/55-ZR17 Dunlop
D207 Sportmax on 5.5" x 17" wheel

ELECTRICS

Battery:12V, 8AH
Ignition:digital with TPS input
Headlight:dual 55W H7

FUEL

Tank capacity:4.8 gal.
Fuel octane recommended:91
High/low/avg. mpg:38.2/35.3/36.7



PERFORMANCE

Measured top speed 155.9 mph
0-1/4 mile11.26 sec.
@ 121.56 mph
0-60 mph3.52 sec.
0-100 mph7.94 sec.
60-0 mph123.53'
Power to Weight Ratio1:4.88
Speed @ 65 mph (indicated)61.3

M/C RATING SYSTEM

EXCELLENT
VERY GOOD
GOOD
FAIR
POOR

Middleweight Sportbike

Engine ●●●●○
Transmission ●●●●○
Suspension ●●●●○
Brakes ●●●●●
Handling ●●●●○
Styling ●●●●○
Riding Impression ●●●●○
Instruments/Controls ●●●●●
Attention to Detail ●●●●●
Value ●●●○○

OVERALL RATING ●●●●○

ERGONOMICS TEMPLATE

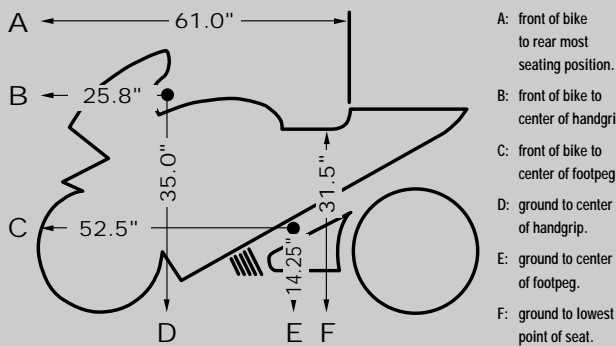

MISCELLANEOUS

Instruments:analog tach,digital
speedo, odometer, dual tripmeters,
clock, fuel gauge, coolant temp.
Indicators: .. hi-beam, t/s, neutral, low
fuel, high coolant/oil pressure warning,
PGM-FI Malfunction
MSRP:\$8499
Routine service interval:.....8000 mi.
Valve adj. interval:.....16,000 mi.
Warranty:12 mo., unlimited miles
Colors: Pearl Yellow/Metallic Titanium,
Candy Blue/Back

DYNAMOMETER DATA

Low end ●●●●○
Mid-range ●●●●○
Top end ●●●●○

The F4i's fuel injection is typical of so many early systems, with abrupt On/Off response, and a hesitant lower-rpm range. Spun hard, it will run very swiftly, but loses out to the ZZR600 by nearly 10 hp at 6000 rpm. However, used as a track-day bike, you'll hardly notice.

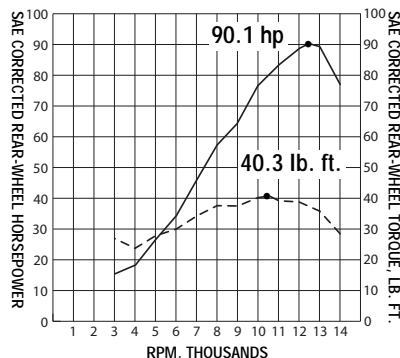

TEST NOTES

PICKS

- The most competent track-day bike in the comparison
- The most up-to-date appearance and sharpest graphics
- Great brake feel

PANS

- A stiff ride that hammers the pilot on rougher roads
- Low- and mid-range hesitation and EFI abruptness
- A price out of line with its competitors'

STANDARD MAINTENANCE

Item	Time	Parts	Labor
Oil & Filter	1.0	\$14.98/\$20	\$60.00
Air Filter	0.5	\$43.99	\$30.00
Valve Adjust	3.0	\$114.25	\$180.00
Battery Access	0.2	MF	\$12.00
Final Drive	0.2		\$12.00
R/R Rear Whl.	1.0		\$60.00
Change Plugs	0.5	\$65.48	\$30.00
Adjust FI	1.0		\$60.00
Totals	7.4	\$258.70	\$444.00