



Although the 600 Monster was Ducati's best-seller in Europe, it has been thoroughly upgraded for its introduction in America. The latest Marelli 5.9 engine management/fuel injection system is fitted in place of carburetors, the stroke has been increased 3.5mm to boost displacement from 583cc to 618cc, new cams, a larger airbox and big-valve heads increase the rev range from 8000 to 9500 rpm, and help to produce 54.3 hp—9 more than before. Vibration is low and with a broad torque curve, and close ratio five speed, it makes for a very satisfying powerplant



No longer do the Monsters come with partial instrumentation. Everything you need is there along with a few extras: oil temp, clock, "time for service" alert (time to check those pesky valve clearances) and low fuel light. An anti-theft "Immobilizer" is also standard, which requires a coded key to start the bike. Even the instrument lighting intensity is adjustable.



Below: The matte black paint on the tank and chassis is not a flat black, as on Honda's new 919, but a more durable satin finish that can be waxed without fear of changing its appearance. We're still partial to Ducati red.



The large 320mm disc and excellent Brembo Goldline caliper feel up to the job in everyday riding, but overheated after one hard stop and increased stopping distances dramatically during testing.



You can choose either from two different seats when you buy. The standard is ??? off the ground, and the optional lower version brings the seat down to just ??? The pillion accommodations leave something to be desired for size and slopes backwards. The rider's perch is more comfortable than it looks, but still quite firm.

## TESTERS' LOG

How much motorcycle do you really need to have fun? The Monster 620ie's nimble, well-balanced chassis and tractable V-twin that lays 54+ horses on the pavement will make you feel like a roadracing hero from the Fifties or Sixties. You're stretched out over the tank, wind in your face, leather boot soles skimming the pavement, effortlessly keeping a surprising pace over a mountain road. As Dick Mann once said, "It's better to ride a slow bike fast, than a fast bike slow." When too many sportbikes can intimidate the best of riders, the 620 works with you, offering you the right tools, great road feel, great brakes, and transparent controls to make you and the machine one.

The quibbles—better mirrors, perhaps a softer seat and a bit more wind protection—are simple enough to fix, but the basic package is right there, and justifies making the effort.

As someone who's always had a soft spot for Ducatis, I could seriously consider buying the 620ie. It would have to be red, though.

The Monster 620ie strips the riding experience to its essentials and answers the question loud and clear... this is enough!

—Dave Searle

I've never liked riding Ducatis. I could appreciate their styling and speed, from a distance, but forget about riding one. Too edgy. Too racy. Too uncomfortable. Not to mention that rattly clutch and hair-trigger throttle. Leave it for the young kneepuck draggers in their fluorescent leathers. When I was invited to the Monster 620 intro, I didn't even want to go, but everyone else was busy, so I gritted my teeth and relented.

What a culture shock to find that the 620ie was a whole different breed of Ducati. Not only were the noisy clutch and twitchy throttle gone, the bike was actually comfortable to ride, and a whale of a lot of fun, to boot. The little 620cc Desmo twin kicks like a hot 750, and the frame and suspension work so well together you'd swear the thing was on rails going around corners. Over the next four weeks, Dave had trouble prying my fingers off it so he could finish the testing. It became my all-time favorite commuter ride and weekend playtoy. Finally, a Ducati for the rest of us!

Forget everything you ever knew about Ducatis except for that sexy styling. This is a whole new ballgame.

—Fred Rau

# 2002 Ducati Monster 620ie Dark

## SPECIFICATIONS AND PERFORMANCE DATA



### ENGINE

Type: .....air-cooled, 90° L-twin  
Valvetrain: ..desmodromic, two valves per cylinder, shim-on-valve-stem  
Size: .....618cc  
Bore/stroke: .....80.0mm x 61.5mm  
Comp. ratio: .....10.7:1  
Fueling: .....Marelli 5.9 EFI with two 45mm throttle bodies  
Exhaust: .....2-1-2

### DRIVE TRAIN

Transmission: .....5-speed  
Final drive: .....No. 530 O-ring chain, RPM @ 65 mph/redline ....4890/9500

### DIMENSIONS

Wheelbase: .....56.7"  
Rake/trail .....24.0°/3.54"  
Ground clearance: .....4.4"  
Seat height: .....29.9"  
GVWR: .....881 lbs.  
Wet weight: .....424 lbs.  
Carrying capacity: .....457 lbs.

### SUSPENSION

Front: 43mm inverted cartridge forks, non-adjustable, 5.1" travel  
Rear: .....Sachs monoshock damper with progressive rocker linkage, adj. preload and reb. damping, 5.8" travel

### BRAKES

Front: .....single 320mm disc, Brembo four-piston, double-action caliper  
Rear: .....245mm disc, twin-piston, double-action caliper

### TIRES & WHEELS

Front: .....120/60ZR17 Dunlop D205 Sportmax on 3.50" x 17" wheel  
Rear: .....160/60ZR17 Dunlop D205 Sportmax on 4.50" x 17" wheel

### ELECTRICS

Battery: .....12V, 12AH  
Ignition: .....digital-mapped with throttle position sensor  
Headlight: .....55/60W

### FUEL

Tank capacity: .....4.0 gal.



### PERFORMANCE

Measured top speed .....116.0 mph  
0-1/4 mile .....12.52 sec. @ 104.24 mph  
0-60 mph .....4.31 sec.  
0-100 mph .....12.29 sec.  
60-0 mph .....113.7'  
Power to Weight Ratio .....1:7.81  
Speed @ 65 mph indicated .....62.5

### M/C RATING SYSTEM

EXCELLENT  
VERY GOOD  
GOOD  
FAIR  
POOR

### Lightweight Standard

Engine ●●●●○  
Transmission ●●●●○  
Suspension ●●●●○  
Brakes ●●●●○  
Handling ●●●●○  
Styling ●●●●○  
Riding Impression ●●●●○  
Instruments/Controls ●●●●○  
Attention to Detail ●●●●○  
Value ●●●●○

OVERALL RATING ●●●●○

### ERGONOMICS TEMPLATE

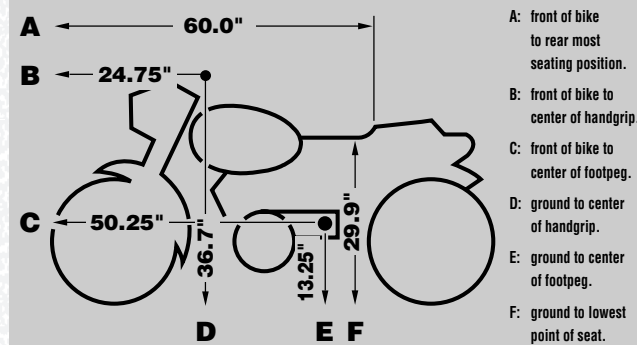

High/low/avg. mpg: ....47.7/56.0/51.9

### MISCELLANEOUS

Instruments: .....speedo, tach, odometer, tripmeter,  
Indicators: .....hi-beam, t/s, neutral, oil pressure, immobilizer, LCD clock  
MSRP: .....\$6495  
Valve adj. interval: .....6000 mi.  
Warranty: .....2 years, unlimited miles.  
Color: .....matte black

Low end ●●●●○  
Mid-range ●●●●○  
Top end ●●●●○

The 620's motor produces plenty of thrust with a wide, torquey powerband. High-tech fuel injection gives excellent throttle response and delivers terrific gas mileage, too. The 90° V-twin is smooth running and looks good exposed.

### DYNAMOMETER DATA

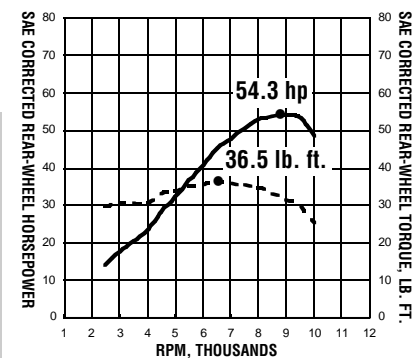

### TEST NOTES

#### PICKS

- Terrific value for the price, especially for a Ducati
- Highly tuned engine doesn't disappoint
- Light weight and good handling adds up to fun

#### PANS

- Clutch shudders and grabs when hot
- Mirrors need to be wider and further forward
- Matte black everything isn't particularly flattering

### STANDARD MAINTENANCE

Item	Time	Parts	Labor
Oil & Filter	0.25	\$12.95 + \$12	\$15.00
Air Filter	0.25	\$33.05	\$15.00
Valve Adjust	3.0	\$71.60	\$180.00
Battery Access	0.2	MF	\$12.00
Final Drive	0.2		\$12.00
R/R Rear Whl.	0.5		\$30.00
Change Plugs	1.0	\$39.80	\$60.00
Synch EFI	0.7		\$42.00
<b>Totals</b>	<b>6.1</b>	<b>\$169.40</b>	<b>\$366.00</b>

Note: MCN Labor rate changed to \$60/hr. from \$54/hr. in May 2002