



Left: Up close, you can see how streamlined the gently rounded nose of the bike is, and also the metallic flecks in its charcoal grey paint. Its stacked polyellipsoidal headlights were originally controversial, but now, we couldn't imagine anything else looking so right. Note the turnsignals, tastefully integrated into the mirrors.



Above: The gorgeous "organ pipe" exhaust is another signature feature. Our bike had the less-restrictive set fitted. These pipes don't cost extra, but come included, along with a remapped ignition chip. They sound incredible at 13,900 rpm!



Above: The shape of the elegant instrument console is repeated in the hydraulic reservoirs on either side. Note the little serial number plaque: "N 007/300."



Right: The front end is full of captivating images; the enormous hollow front axle that begs you to peek through to the other side, the six-piston Nissan calipers, the Ti-Nitride-coated fork legs, the racing style drop-out axle carriers, and even the disc carriers are works of art. The front fender is carbon fiber, naturally, on a limited edition like the Senna.



Left: An image that captures the voluptuous shapes of Massimo Tamburini's latest sculpture. Originally destined to be the shape of the successor to the Ducati 916/998 series, after the American buyout, Tamburini and Galuzzi left Ducati to create the MV Agusta for Claudio Castiglione. We think Count Agusta, himself, would be proud of the F4.



Left: Note the ride height adjuster in front of the back tire, and the multi-adjustable shift linkage. The circular item in front of the footpeg is another eccentric mounting adjuster.

## TESTERS' LOG

Sometimes you have to pinch yourself, being a tester. Having the occasion to ride different motorcycles is seldom a tedious experience, especially aboard machines that could be considered exotic. The F4 Senna fits the bill for specialized. Taught suspension, a close ratio gearbox with tall final drive gearing and a 14,000-rpm ceiling. It was designed with European type riding in mind. Which way to the autobahn? And although it would appear so, it's not merely eye candy, but a focused and capable tool that loves to be exploited. Something I found interesting is that with the possible exception of the rear shock, I would choose not to change any other single part with aftermarket pieces. 007 is pleasing to the eye and works as good as it looks. That's saying a lot, and besides, Ayrton was my favorite driver. —Danny Coe

My interest in MV Agusta first began shortly after I started cup racing in 1975. As a teen and newcomer to the world of motorcycle road racing, I was immediately drawn by the legend of Agostini and the history of the famous Italian company. MV's incredible accomplishment of 37 championships still remains a record today.

Along with my early love of racing history came the hope to own an MV Agusta, and some 25 years later, I was one of the first people to sign-up for a new MV after learning of their return.

When my first MV arrived, it was beautiful, having everything I imagined and more. Ferrari technology with radial valves, fuel injection, cassette gearbox, it was sleek from nose to tail. Sitting on this motorcycle felt like putting on a glove—everything fit exactly as it should. With stable geometry and perfect balance it made a smooth, comfortable ride, especially at higher and higher speeds.

The truly special part of the MV is riding it. Although she's not the torque monster in the garage, when my friends call and plan for longer sporting adventures; the MV's key is the one I look for. This motorcycle is in a class of its own. —Kaming Ko

Kaming is the sort of person you would imagine would own an MV Agusta; someone who appreciates its exclusivity and technology but doesn't let its price prevent him from riding it hard and well. Thanks for sharing, Kaming! —Dave Searle

# 2002 MV Agusta F4 Senna

## SPECIFICATIONS AND PERFORMANCE DATA

### ENGINE

Type: .....liquid-cooled, inline four  
Valvetrain: ..DOHC, radial 4 valves per cyl., adjusting shims under buckets  
Displacement: .....749.4cc  
Bore/stroke: .....73.66mm x 43.18mm  
Comp. ratio: .....12.0:1  
Carburetion: Marelli 1.6 Fuel injection, 45 mm throttle bodies  
Exhaust: .....4-1-4

### DRIVE TRAIN

Transmission: .....6-speed  
Final drive: .....#530 chain  
RPM @ 65 mph/redline ..5325/13,900

### DIMENSIONS

Wheelbase: .....55.04"  
Rake/trail: .....N/A°/3.87"  
Ground clearance: .....3.8"  
Seat height: .....32.25"  
GVWR: .....717 lbs.  
Wet weight: .....481 lbs.  
Carrying capacity: .....236 lbs.

### SUSPENSION

Front: 49mm inverted cartridge forks, adj. preload, comp. and reb. damping, 4.65" travel  
Rear: monoshock w/progressive link, adj. preload, comp. and reb. damping, 4.72" travel

### BRAKES

Front: .....dual 310mm discs, six-piston, double-action calipers  
Rear: .....210mm disc, four-piston, double-action calipers

### TIRES & WHEELS

Front: **120/65ZR17** Pirelli Dragon Corsa MTR21 on **3.50" x 17"** wheel  
Rear: **190/50ZR17** Pirelli Dragon Corsa MTR22 D208 on **6.00" x 17"** wheel

### ELECTRICS

Battery: .....12V, 9AH  
Ignition: .....Weber-Marelli digital  
Headlight: .....stacked projector beams  
60W high, 55W low

### FUEL

Tank capacity: .....5.52 gal.  
High/low/avg. mpg: ....47.2/29.7/33.4

## CycleStats™

### PERFORMANCE

Measured top speed .....170.9 mph  
0-1/4 mile .....10.85 sec.  
@ 131.85 mph  
0-60 mph .....3.50 sec.  
0-100 mph .....6.85 sec.  
60-0 mph .....122.3'  
Power to Weight Ratio .....1:4.12  
Speed @ 65 mph indicated ....62.3

### M/C RATING SYSTEM

EXCELLENT  
VERY GOOD  
GOOD  
FAIR  
POOR

### Open Sportbike

Engine ●●●●●  
Transmission ●●●●○  
Suspension ●●●●●  
Brakes ●●●●●  
Handling ●●●●●  
Styling ●●●●●  
Riding Impression ●●●●●  
Instruments/Controls ●●●●●  
Attention to Detail ●●●●●  
Value ●●●○○  
OVERALL RATING ●●●●●



### ERGONOMICS TEMPLATE

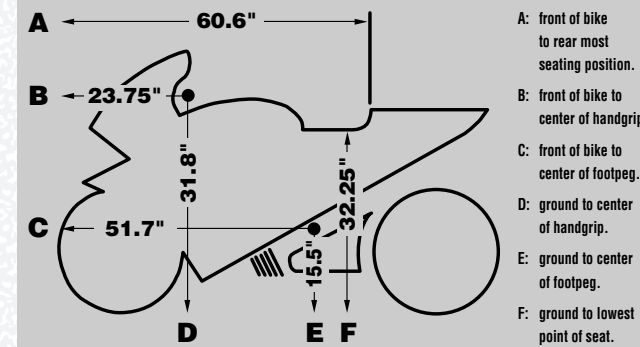

### MISCELLANEOUS

Instruments: electronic LCD speedo & analog tachometer, digital odometer, dual tripmeter, coolant temp., lap timer  
Indicators: ..... hi-beam, t/s, neutral, battery charge, sidestand warning, rev limit warning @ 13,600 rpm  
MSRP: .....\$24,995  
Valve adj. interval: .....first at 600 mi., every 7500 mi. thereafter  
Warranty: .....2 year., unlimited miles  
Colors: .....Metallic Black/Silver Grey w/ Red frame and wheels

### DYNAMOMETER DATA

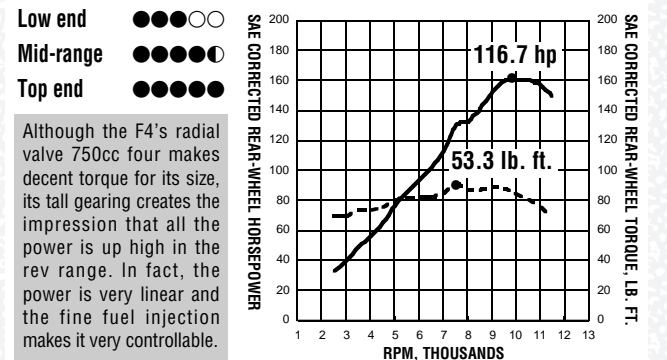

### TEST NOTES

#### PICKS

- Spares kits with de-restricted exhaust, chip and gearing
- Top shelf Showa fork with drop-out axle
- Stunning appearance matched with a thrilling sound

#### PANS

- Lack of adequate thumb clearance at full lock
- Left headers must be removed to change oil filter
- The fact that we can't afford one

### STANDARD MAINTENANCE

Item	Time	Parts	Labor
Oil & Filter	1.5	\$15.50 + \$24	\$90.00
Air Filter	0.5	\$31.85	\$30.00
Valve Adjust	4.5	\$38.08	\$270.00
Battery Access	0.2	MF	\$12.00
Final Drive	0.2		\$12.00
R/R Rear Whl.	0.4		\$24.00
Change Plugs	0.8	\$30.00	\$48.00
Synch EFI	0.3		\$18.00
<b>Totals</b>	<b>8.4</b>	<b>\$139.43</b>	<b>\$504.00</b>

Note: MCN Labor rate changed to \$60/hr. from \$54/hr. in May 2002